

Technical data RHK-AK 75

without e-filter

transport width (mm)	890
transport length (mm)	1595
transport height (mm)	1670
width with cover panel (mm)	1085
length with cover panel (mm)	1690
height with cover panel (mm)	1645
water content (l)	385
weight (kg)	1400
heat exchanger surface (m ²)	7,20
continuous heat load (kW)	0-75
heating output (kW)	75
CO ² (%)	10,0
efficiency (%)	>90
flue gas mass flow (kg/s)	0,067000
flue gas temperature (°C)	180
flue depress (PA)	14
flue depress with underpressure monitoring (PA)	10
drop at dT 10 pressure K (mbar)	15,20
max. pressure (bar)	3
flow heat (inch)	1 1/2
heat return (inch)	1 1/2
inchflow (inch)	1
safety return (inch)	1
filling and emptying (inch)	1/2
thermowell (inch)	1/2
flue gas pipe diameter (mm)	200
min. opening for air supply (cm ²)	200
min. volume flow rate for return temp. increase at 15K (m ³ /h)	1,43

Electrical connection data

Boilers up to 100 kW

Connection	400V / 3N PE CEE plug 16A
Protection	C 16A
RCD switch	Type A IΔN 30mA

The boiler should be accessible from three sides. The discharging system should not cross the heating room. Room height and position of the particle separator(s)* should be discussed with the Heizomat team. Connecting points for the necessary potential equalization on the boiler see supplementary sheets "Connection of the Heizomat boiler system to the main potential equalization of a building" *.

Technical changes that serve the permanent further development remain reserved.

*Optional equipment, depending on the statutory provisions for the country of destination.

Status 01.07.2017

Heizomat GmbH Gerätebau- Energiesysteme
Maicha 21 - 91710 Gunzenhausen - 09836/9797-0

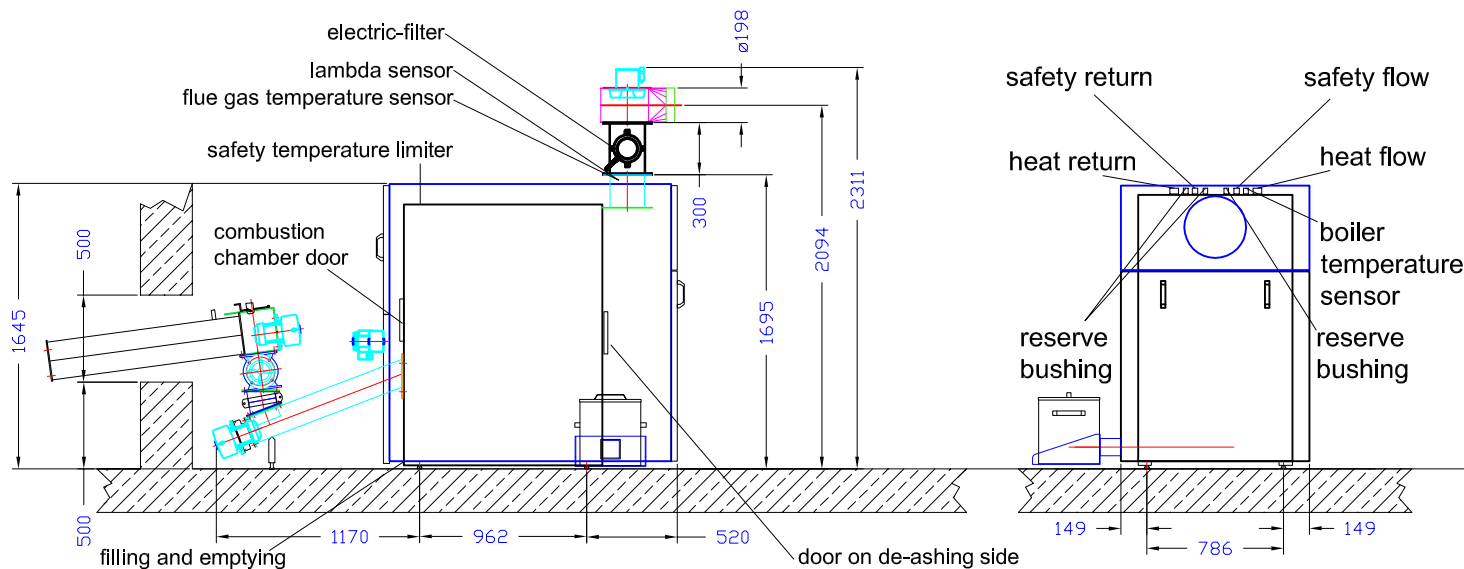
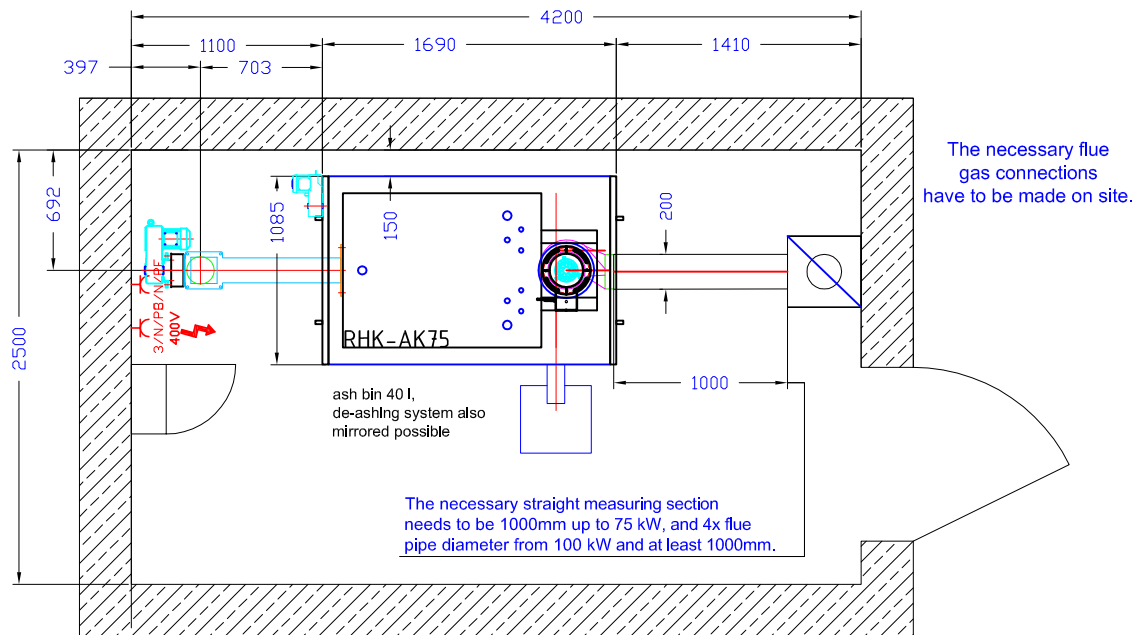

Technical data RHK-AK 75 with e-filter	
transport width (mm)	890
transport length (mm)	1595
transport height (mm)	1670
width with cover panel (mm)	1085
length with cover panel (mm)	1690
height with cover panel (mm)	1645
water content (l)	385
weight (kg)	1400
heat exchanger surface (m ²)	7,20
continuous heat load (kW)	0-75
heating output (kW)	75
CO ² (%)	10,0
efficiency (%)	>90
flue gas mass flow (kg/s)	0,067000
flue gas temperature (°C)	180
flue depress (PA)	14
flue depress with underpressure monitoring (PA)	10
drop at dT 10 pressure K (mbar)	15,20
max. pressure (bar)	3
flow heat (inch)	1 1/2
heat return (inch)	1 1/2
inchflow (inch)	1
safety return (inch)	1
filling and emptying (inch)	1/2
thermowell (inch)	1/2
flue gas pipe diameter (mm)	200
min. opening for air supply (cm ²)	200
min. volume flow rate for return temp. increase at 15K (m ³ /h)	1,43

Electrical connection data Boilers up to 100 kW	
Connection	400V / 3N PE CEE plug 16A
Protection	C 16A
RCD switch	Type A IΔN 30mA

Technical data electric-filter	
Heizoclean EF185, electrostatic	1x in flue pipe 200



Heizomat GmbH Gerätebau- Energiesysteme
Maicha 21 - 91710 Gunzenhausen - 09836/9797-0

The boiler should be accessible from three sides. The discharging system should not cross the heating room. Room height and position of the particle separator(s)* should be discussed with the Heizomat team. Connecting points for the necessary potential equalization on the boiler see supplementary sheets "Connection of the Heizomat boiler system to the main potential equalization of a building" *.

Technical changes that serve the permanent further development remain reserved.

*Optional equipment, depending on the statutory provisions for the country of destination.

Status 01.07.2017